

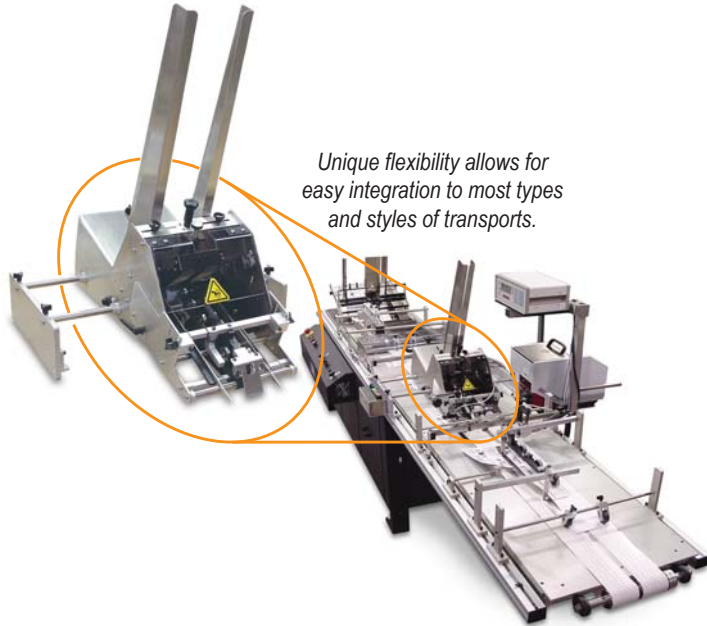

## Tip-On / Affixing Model Converge 900

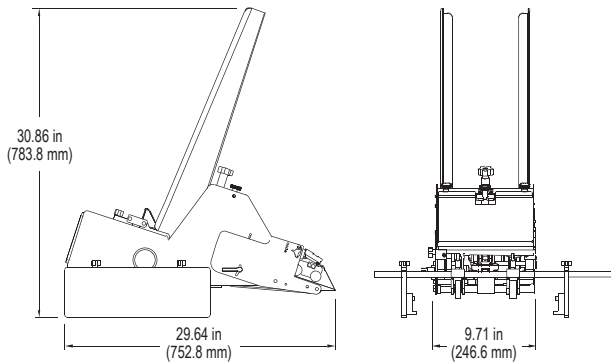

Unique flexibility allows for easy integration to most types and styles of transports.



### Specifications

<b>Maximum Product Size:</b>	7 W x 6 L in (177 x 152 mm)
<b>Minimum Product Size:</b>	2 W x 2.5 L in (50 x 63 mm)
<b>Min/Max Product Thickness:</b>	.003-.250 in (.076 x 6.35 mm)
<b>Belt Speed:</b>	24,000 in/min (609,600 mm/min)
<b>Placement Tolerance:</b>	Steady speed up to +/- 1/16 in (1.58 mm)
<b>Electrical Requirements:</b>	115/230vac, 10A
<b>Air Requirements:</b>	4-6 CFM
<b>Weight:</b>	60 lbs. (27.22 kg)
<b>Warranty:</b>	One-year limited

### Overview:

The Converge 900 is the most accurate, innovative high-speed product placement solution available. The Converge 900 precisely places products at high-speed onto carrier pieces traveling on a variety of transports. Singulates and dispenses the widest range of material types and sizes.

### Applications:

- Gift cards onto a hanging backer
- Promotional documents onto magazines
- Folded documents onto cartons/boxes
- Embossed credit cards onto folded/unfolded paper carriers

### Features:

Servo Motor and Controller

### Advantages:

High-speed stopping accuracy.

### Benefits:

+/- 1/16" Placement tolerance.

### Modular Design

Can be purchased stand-alone, added to existing equipment or configured as a complete system. Use on multiple pieces of host equipment.

Low initial investment. Enables system to process largest variety of products. Utilizes existing resources.

### Placement Position Adjustment

Placement position can be set or adjusted on the fly.

Quickly & accurately adjust product position on the run.

### Vacuum Assist

Vacuum feed capability is standard.

No struggling with coated or slick stocks.

### Articulating Discharge Section

Height can be raised without changing tip-on position.

Increases feeder mounting options and system flexibility.

### Optional Alignment Section

True fully-adjustable side registration.

Tighter tolerances and improved product quality.

315 27th Avenue NE · Minneapolis, MN 55418 · USA  
(763) 502-0000 · www.streamfeeder.com · E-mail: sales@streamfeeder.com

# Barry-Wehmiller