

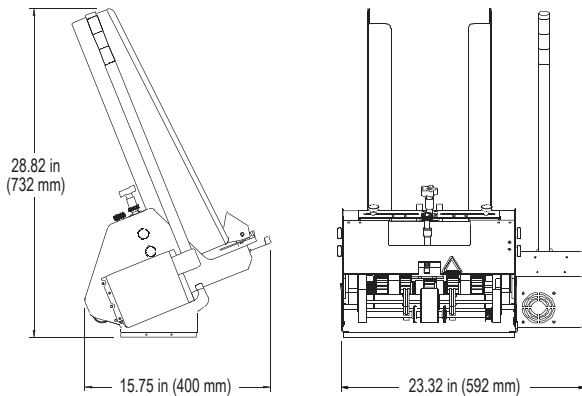

Pro Series - Feeder/Dispenser Model ST-1450



Overview:

The ST-1450 has been designed for high-performance feeding and dispensing. Its intelligent system controller provides easy feature configuration. Compact footprint is ideal for in-line conveyor mounting. Use it in stand-alone applications as well as integrating into other systems. The ST-1450 is capable of handling a wide variety of products, from single sheets to thick magazines.

Applications:

- Software packaging
- Collating
- Batch counting
- Sheet feeding
- Forms
- Greeting cards
- Inserts

Features:

Minimal Adjustment Points

Advantages:

Three adjustment points for product change-over. Single knob adjustments.

Benefits:

Faster make-ready gets more jobs out the door. Skilled operators not needed for change-over.

Easy Remove Carriage

Carriage can be removed quickly and easily for belt changes.

Reduces down time for preventative maintenance.

Optional Vacuum Assist

Helps keep coated stock from slipping.

No struggling with coated or slick stocks.

Thick Product Capability

Feed product from .003" to 1.0".

More jobs can be run on the same machine.

I-Quipped Keypad/Display Control Interface

Ease of set up, operation, and monitoring of feeder.

Makes operator more productive in set up and operation of feeder.

Specifications

Maximum Product Size:	14.5 W x 9 L in (368 x 228 mm)
With Optional Deck Extension:	14.5 W x 14 L in (368 x 355 mm)
Minimum Product Size:	3.75 W x 2.5 L in (95 x 63 mm)
Optional:	2 W x 2.5 L in (51 x 63 mm)
Min/Max Product Thickness:	.003-1.0 in (.076-25.4 mm)
Belt Speed:	5500 in/min (140,000 mm/min)
Electrical Requirements:	115/230vac, 50/60Hz, 3A
Weight:	84 lbs. (40.367kg)
Warranty:	One-year limited

315 27th Avenue NE · Minneapolis, MN 55418 · USA
(763) 502-0000 · www.streamfeeder.com · E-mail: sales@streamfeeder.com

Barry-Wehmiller

ACCRAPLY

Barry-Wehmiller
Company



pneumatic
SCALE ANGELUS

Thiele
Technologies

DESIGN GROUP

Barry-Wehmiller
International Resources

Hayssen Sandiacre

Marquip Ward United

Fleetwood Goldco Wyard