



Value Series - Feeder/Dispenser Model V-710BC



Overview:

The V-710BC provides dependable one-shot feeding and batch count feeding of a wide variety of products. Ideal for collating and mail inserting applications that operate at speeds up to 100 cycles per minute. Simple tool-less adjustments for quick setups and changeovers.

Applications:

- Collating
- Batch Counting
- Accumulating
- Kit Fulfillment
- Package Inserting
- Automatic Wrapping

Features:

Minimum Adjustment Points

Advantages:

4 adjustment points for product changeover. Single knob adjustment.

Benefits:

Faster make-ready. Get more jobs out the door. Skilled operators not needed for changeovers.

Thick Product Capability

Feed products that are .003" - .75" thick.

Run more jobs on the same machine.

Variable Angle Feed Belts

Enhanced feeder performance.

Allows you to bid a wider spectrum of jobs.

Light Weight Construction

Portable.

Easy to move and setup.

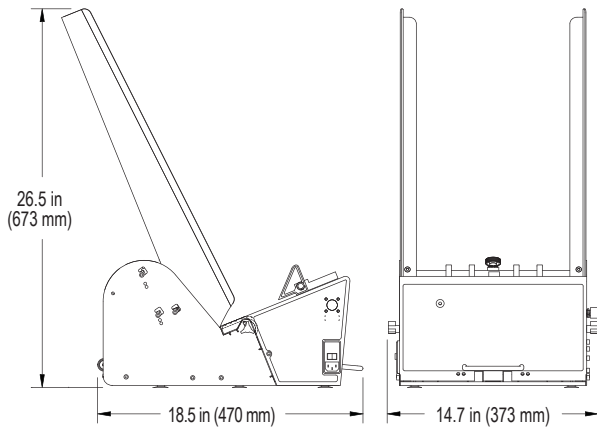

Specifications

Maximum Product Size:	12 W x 12 L in (305 x 305 mm)*
Minimum Product Size:	3.75 W x 3.75 L in (95 x 95 mm)
Optional:	2.5 W x 2.5 L in (63 x 63 mm)
Min/Max Product Thickness:	.003 - .75 in (.076-19 mm)
Belt Speed:	4000 in/min (101,600 mm/min)
Batch Size:	1-50 pieces
Electrical Requirements:	115/230vac, 50/60Hz, 3A
Weight:	43 lbs. (19.5kg)
Warranty:	One-year limited

*Optional product size available

315 27th Avenue NE · Minneapolis, MN 55418 · USA
(763) 502-0000 · www.streamfeeder.com · E-mail: sales@streamfeeder.com

Barry-Wehmiller

ACCRAPLY

Barry-Wehmiller
Company



pneumatic
SCALE ANGELUS

Thiele
Technologies

DESIGN GROUP

Barry-Wehmiller
International Resources

Hayssen Sandiacre

Marquip Ward United

Fleetwood Goldco Wyard