



## Modular Collator Base

### Overview:

Designed to be a flexible and innovative solution to even the most challenging applications. Completely configurable for your application with right to left, left to right, or optional dual-direction operation. Easily expandable with optional Middle Sections that can be added as system requirements expand.

### Applications:

- Collating
- Batch Counting
- Accumulating
- Kit Fulfillment
- Automatic Wrapping

### Features:

Minimum Adjustment Points

### Advantages:

Simple tool-less adjustments.

### Benefits:

Faster make-ready. Get more jobs out the door. Skilled operators not needed for change-overs.

Portable

Mounted on casters allows free movement.

Can be moved easily from one application to another.

Expandable 4.5' Sections

Flexibility to easily expand as business grows.

Increased capacity at a lower cost.

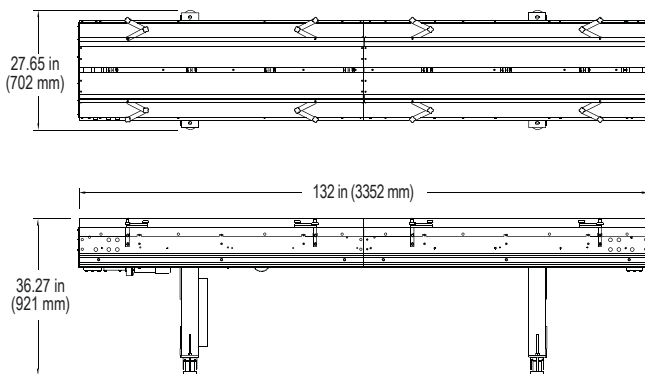

### Specifications

<b>Maximum Product Size:</b>	18 W x 12 L in (457 x 304 mm)
<b>Minimum Product Size:</b>	3 W x 3 L in (76 x 76 mm)
<b>Speed:</b>	0-2160 in/min (54,864 mm/min)
<b>Conveyor Length:</b>	11 ft (3352 mm)
<b>Conveyor Height:</b>	Adj. Max. 38 in (965 mm) Min. 34 in (864 mm)
<b>Side Guide Height:</b>	2 in (51 mm)
<b>Lug Width/Height:</b>	1 in (25.4 mm)/1.875 in (47.6 mm)
<b>Lug Spacing:</b>	18 in (457 mm)
<b>Electrical Requirements:</b>	115/230vac, 50/60Hz, 15A
<b>Weight:</b>	600 lbs. (272kg)

315 27th Avenue NE · Minneapolis, MN 55418 · USA  
 (763) 502-0000 · www.streamfeeder.com · E-mail: sales@streamfeeder.com

# Barry-Wehmiller