



Value Series - Feeder/Dispenser Model V-1000



Overview:

The V-1000 is the next generation of continuous feeding technology in our Value Series. The V-1000 features quick and tool-less setup, quick make-ready, and easy maintenance. It is capable of feeding a wide variety of materials at high speed with exceptional alignment qualities. CE certified.

Applications:

- Mail Processing
- Ink Jet Bases
- Labeling Bases
- Tabber Bases
- Folding Machines
- Reinforcing Machines

Features:

Movable Feed Belts

Advantages:

Position belts for optimum product feeding.

Benefits:

Consistently feed a wide variety of products straight.

Movable Product Separators

Separate product either on or off the belts.

Separate products that vary in thickness.

Quick Release Side Guides

Allows side guides to easily pass over belts.

Faster setup increases productivity.

Single Knob Side Guide Adjustment

Individual side guide position adjustment.

Reduces operator setup time.

Quick Change Carriage

Faster belt replacement.

Reduces downtime.

Quick Access Service Panel

Easy access to controls and electronics.

Simple, efficient maintenance.

Universal Electronic Interface Kit

Interface the start/stop function with most systems.

Ability to integrate with most mailing bases.

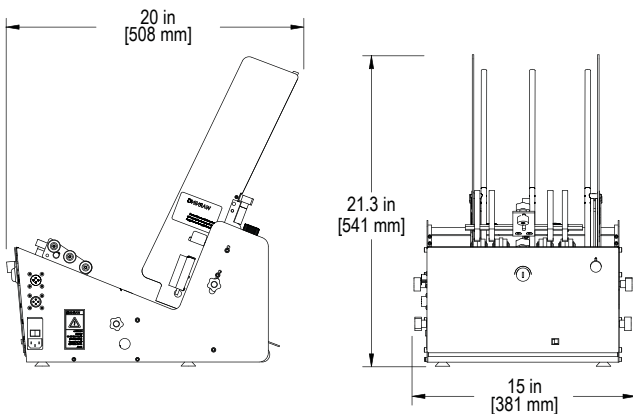

Specifications

Maximum Product Size:	12 W x 12 L in (304.8 x 304.8 mm)
Minimum Product Size:	2 W x 3 L in (50.8 x 76.2 mm)
Min/Max Product Thickness:	.003-1.0 in (.07-25.4 mm)
Belt Speed:	7800 ipm (19,812 cm/min)
Electrical Requirements:	115vac, 60Hz, 3A 230vac, 50/60Hz, 1.5A
Weight:	47 lbs. (21.3kg)
Warranty:	Two-year limited

315 27th Avenue NE · Minneapolis, MN 55418 · USA
(763) 502-0000 · www.streamfeeder.com · E-mail: sales@streamfeeder.com

Barry-Wehmiller

ACCRAPLY

Barry-Wehmiller
Company



pneumatic
SCALE ANGELUS

Thiele
Technologies

DESIGN GROUP

Barry-Wehmiller
International Resources

Hayssen Sandiacre

Marquip Ward United

Fleetwood Goldco Wyard