

## Value Series - Feeder/Dispenser Model V-710DM



### Overview:

The V-710DM provides the flexibility of automating “jumbo” format gripper arm inserters and ink jet/tabber bases. The V-710DM allows for quick and easy installation onto most major brands of vacuum/non-vacuum bases and gripper arm inserters. Increases the throughput and reliability of addressing bases.

### Applications:

- Gripper arm inserters
- Ink jet bases
- Labeling bases
- Tabber bases

### Features:

- Large capacity hopper - easy two knob adjustment
- Tool-free adjustments for quick setup and changeover
- Variable angle feed belts enhance feeding performance
- Variable speed control for synchronous operation
- Durable lightweight construction
- Easy to learn and operate

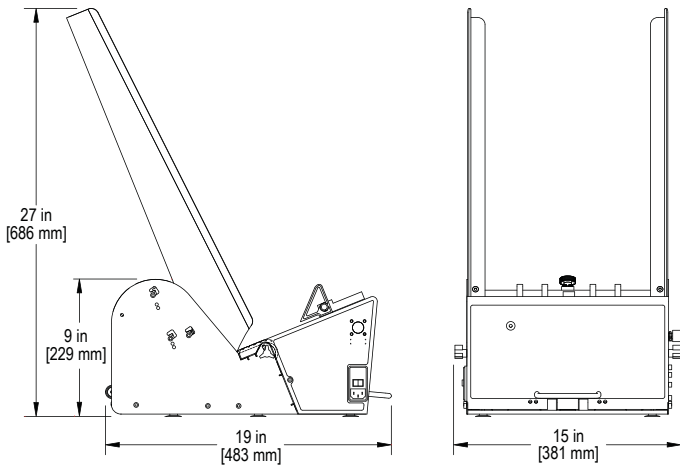

### Specifications

<b>Maximum Product Size:</b>	12 W x 12 L in (305 x 305 mm)*
<b>Minimum Product Size:</b>	3.75 W x 3.75 L in (95 x 95 mm)
Optional:	2.5 W x 2.5 L in (63 x 63 mm)
<b>Min/Max Product Thickness:</b>	.003-.75 in (.076-19.1 mm)
<b>Belt Speed:</b>	4000 in/min (101,600 mm/min)
<b>Electrical Requirements:</b>	115/230vac, 50/60Hz, 3A
<b>Weight:</b>	41 lbs. (18.6kg)
<b>Warranty:</b>	Two-year limited

\*Optional product size available