

Value Series - Feeder/Dispenser Model V-500



Overview:

The V-500 is designed to increase your 6x9 inserting, addressing base, and tabber base productivity. Adding a V-500 to each station dramatically boosts inserter productivity. The V-500 precisely separates, singulates, and presents many types and sizes of materials such as Z-fold sheets, slick stock, payment booklets, and other materials that are typically difficult to feed.

Applications:

- Gripper arm inserters
- Ink jet bases
- Labeling bases
- Tabber bases

Features:

- Large capacity hopper - easy two knob adjustment
- Tool-free adjustments for quick setup and changeover
- Compact width for side-by-side mounting
- Variable speed control for synchronous operation
- Durable lightweight construction
- Easy to learn and operate

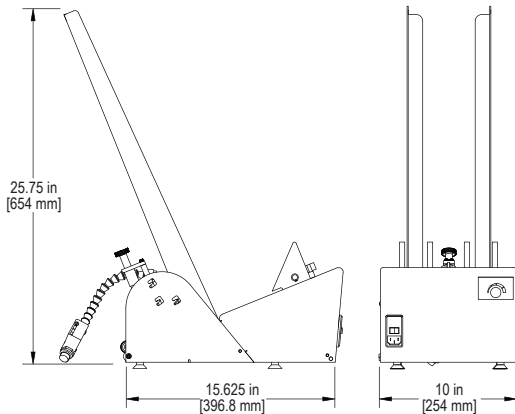

Specifications

Maximum Product Size:	9.25 W x 11 L in (235 x 279 mm)
Minimum Product Size:	2.125 W x 2.5 L in (54 x 63.5 mm)
Min/Max Product Thickness:	.003-.625 in (.076-15.8 mm)
Belt Speed:	3400 in/min (86,360 mm/min)
Electrical Requirements:	115vac, 60Hz, 3A
Weight:	32 lbs. (14.5 kg)
Warranty:	Two-year limited